

## Universal milling frame

# Universal milling frame

as well fitting installation aid for SIMONSWERK routing templates



## Notes

### Fitting instructions

1. Secure the clamping device to the routing frame using the clamp rods.
2. Roughly adjust the clamping device according to rebate construction and fix in place with fastening screws.
3. Place the milling frame on the workpiece.
4. Insert routing template and roughly adjust using the standard values given for rail and angle.
5. Carry out fine adjustment using spindles.
6. Clamp routing frame to workpiece with clamping wheel.

### Scope of supply

- 1 x universal frame
- 1 x clamping device

### Note

Routing templates need to be ordered separately.

## Suitable for

- TE 240 3D
- TE 340 3D
- TE 526 3D
- TE 527 3D
- TE 540 3D
- TE 640 3D
- TE 380 3D

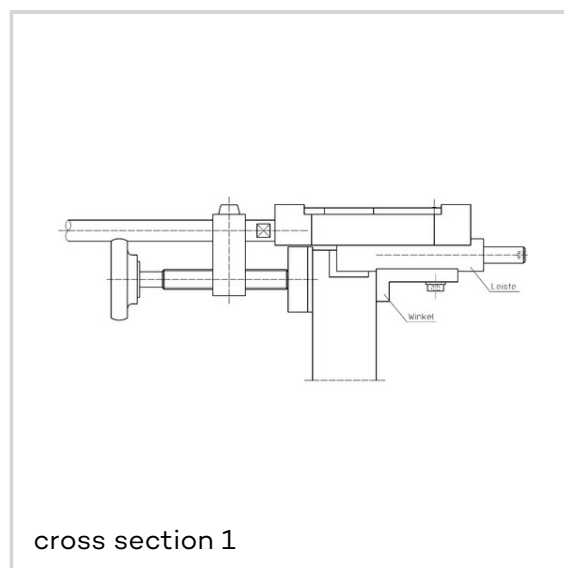

cross section 1

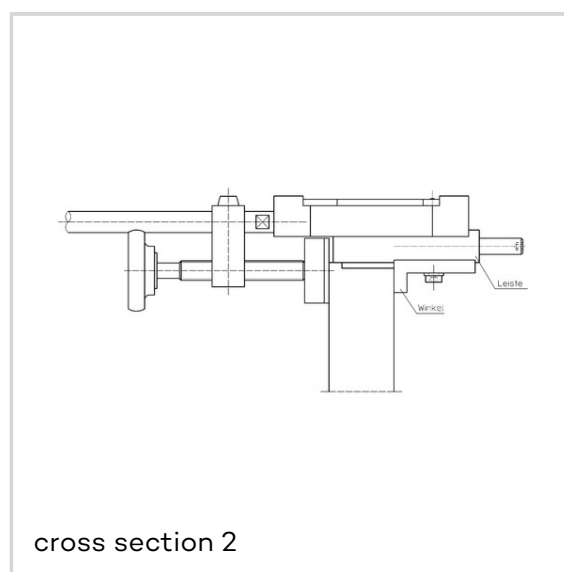

cross section 2

## Universal milling frame

TE 311 3D FVZ 44  
 TE 541 3D FVZ  
 TE 540 3D A8  
 TE 640 3D A8  
 TE 626 3D A8  
 TE 240 3D Energy  
 TE 340 3D Energy  
 TE 526 3D Energy  
 TE 527 3D Energy  
 TE 540 3D Energy  
 TE 640 3D Energy  
 TE 540 3D A8 Energy  
 TE 640 3D A8 Energy  
 TE 626 3D A8 Energy  
 TE 340 3D FR  
 TE 540 3D FR  
 TE 640 3D FR  
 TE 540 3D A8 FR  
 TE 640 3D A8 FR  
 TEG 310 2D 60  
 TEG 310 2D 80  
 VX 7939/100  
 VX 7939/100 FD  
 VX 7939/120  
 VX 7939/160 Planum  
 VX 7939/160 FD Planum  
 VX 7939/160 18-3  
 VX 7939/160 18-3 FD  
 VX 7939/160  
 VX 7939/160 FD  
 VX 7939/160-4 FD 18/5  
 VX 7939/160 S  
 VX 7939/160 FD S  
 VX 7939/160 S WK MSTs  
 VX 7939/160 FD S WK  
 MSTs  
 VX 7939/160-4  
 VX 7939/160-4 FD  
 VX 7939/160-4 FD 18/12  
 VX 7939/160-4 Bronze  
 VX 7939/160-4 Bronze FD  
 VX 7939/160-4 VBRplus  
 VX 7939/160-4 FD  
 VBRplus

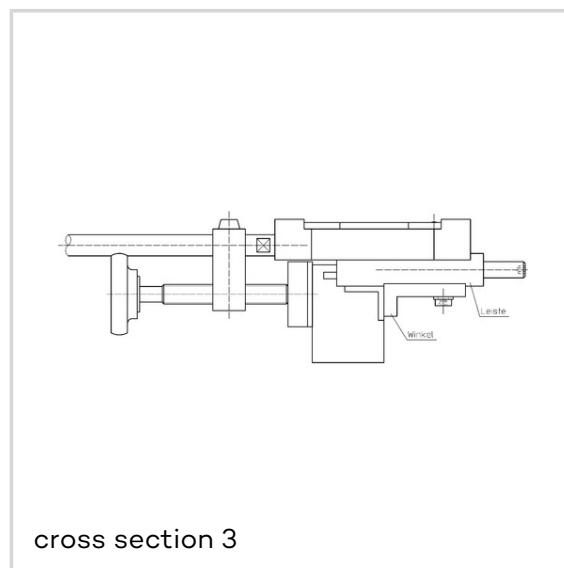

---

**Universal milling frame**

VX 7099 Finger Protection  
VX 8939/160  
VX 7728/100  
VX 8849/160  
VX 7728/120  
VX 7859/120  
VX 7728/160  
VX 7859/160-4  
VX 7859/160-4 FD  
VX 7859/160-4 FD 18/12  
VX 7729/100  
VX 7729/120  
VX 7729/160 Planum  
VX 7729/160 18-3  
VX 7729/160  
VX 7729/160-4  
VX 7749/160-4 40 Care  
VX 7749/160-4 45 Care  
VX 7749/160-4 50+65  
Care  
VX 7749/160-4 70 Care  
VX 7729/160-4 Bronze  
VX 7729/160-4 VBRplus  
VX 2501 3D N  
VX 7501 3D  
VX 7531 3D  
VX 2502 3D N  
VX 7502 3D  
VX 7532 3D  
VX 2505 3D N  
VX 7505 3D  
VX 7535 3D  
VX 2560 KK N  
VX 2560 RK N  
VX 2560 KR N  
VX 2560 RR N  
VX 2570 KK N  
VX 2570 KR N  
VX 2570 RR N  
VX 7560 KK  
VX 7560 RK  
VX 7560 KR  
VX 7560 RR

---

**Universal milling frame**

VX 7561 KK  
VX 7729/160-4 HA MSTS  
with VX 7531 3D and VX  
7561 KK  
VX 7561 KR  
VX 7729/160-4 HA MSTS  
with VX 7531 3D and VX  
7561 KR  
VX 7570 KK  
VX 7570 RK  
VX 7570 KR  
VX 7571 KK  
VX 2580 N  
VX 2590 N  
VX 7580  
VX 7581  
VX 7590  
VX 7591  
VN 1939/100  
VN 3839/100  
VN 1937/120 Compact  
Planum  
VN 1939/120  
VN 1937/160 Compact  
Planum  
VN 1939/160  
VN 1939/160 FD  
VN 3838/160  
VN 3838/160 FD  
VN 2828/100  
VN 2828/120  
VN 5959/120  
VN 2828/160  
VN 5959/160  
VN 2929/100  
VN 3949/100  
VN 2927/120 Compact  
VN 2927/120 Compact  
Planum  
VN 2929/120  
VN 3848/160  
VN 3948/160  
VN 2927/160 Compact  
Planum  
VN 2929/160

---

**Universal milling frame**

VN 2929/160 Planum  
VN 2927/160 Compact  
VN 3939/100  
VN 3939/100 FD  
VN 4739/100  
VN 3938/160  
VN 8939/100 M  
VN 8939/100 FD M  
VN 8938/160  
VN 8938/160 FD  
VN 8849/100 M  
VN 8948/160  
VN 3737/160 Compact  
VN 3738/160  
VN 3738/160 FD  
VN 8937/160 U Compact  
VN 8938/160 U  
VN 8938/160 U FD  
VN 3747/160 Compact  
VN 3748/160  
VN 8947/160 U Compact  
V 0030  
V 0080  
V 0081  
V 0037 WF  
V 0037 WF FD  
V 0037 WF S  
V 0037 WF FD S  
V 0086 WF  
V 0087 WF  
V 4437 WF ZK  
V 0037 WF FV  
V 0037 WF FV S  
V 8535  
V 7888 WF  
V 7888-32 WF  
V 7601 3D  
V 7602 3D/1  
V 7602 3D/3  
V 7502 3D  
Door security bolt no. 205  
Door security bolt no. 206  
Door security bolt no. 207

---

**Universal milling frame**

KCM 50  
KCM 50/50  
KCM 50/H

**Item versions**

---

Finish	without (SW 000)
VPE	Pack of 1
DIN	DIN right and left hand
Article number	5 250930 0 00001
EAN	4015471041427