

KEEP CLOSED - KCM 50**KCM 50**

closing magnet for a contactless and silent closing process of glass and timber doors

**Product features**

- continuous adjustable retention force up to 50 N
- for use in timber, steel and aluminium frames

Technical data

Property	Value
Overall length	195.0 mm
Overall width	13.0 mm
Cutter diameter	12.0 mm
Collar ring diameter	30.0 mm

Installation tools

Universal milling frame

Template 5 251148 5

Template 5 251149 5

step 1

step 2

Combinations

KCH 1700

KCM 50/G

KCM 50/H

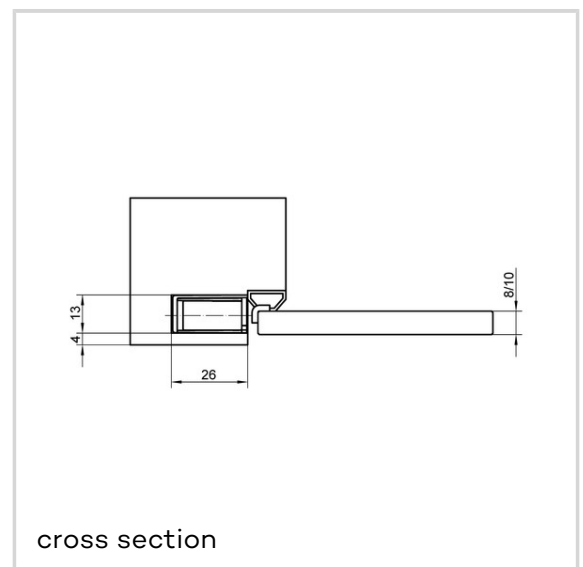
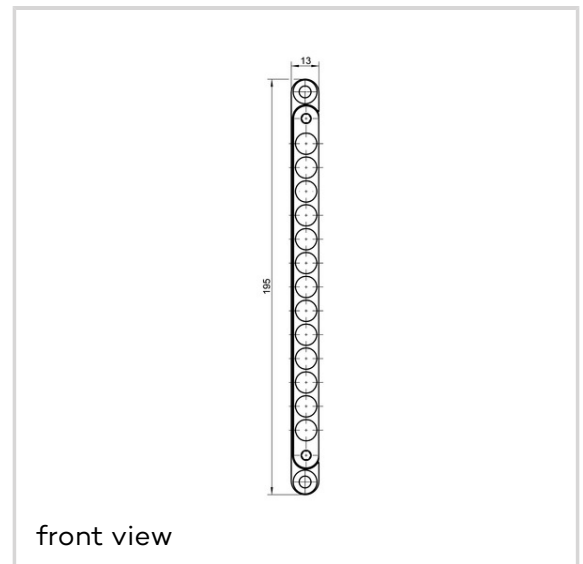

KEEP CLOSED - KCM 50

KCM 50/H FZ
KCM 50 FZ

Item versions

Finish	RAL 9005 Matte Black (SW 107)
VPE	Pack of 1
DIN	DIN right and left hand
Article number	5 170855 0 10701
EAN	4015471145514
Finish	Stainless Steel Effect (SW 130)
VPE	Pack of 1
DIN	DIN right and left hand
Article number	5 170855 0 13001
EAN	4015471130947
Finish	Stainless Steel Effect (SW 130)
VPE	Pack of 10
DIN	DIN right and left hand
Article number	5 170855 0 13006
EAN	4015471131111